

Tell me more about the ASPPA Credentialing Programs.

ASPPA offers four credentialing tracks, supporting seven distinct credentials and three certificate programs, for retirement plan professionals. The coursework and examinations required for each credential are as follows:

Plan Administration, Compliance and Consulting Track

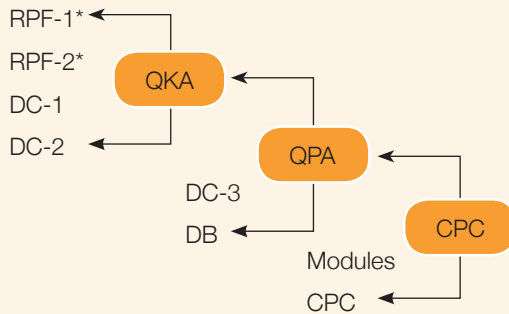

The Qualified 401(k) Administrator program (QKA) focuses on 401(k) plan recordkeeping, nondiscrimination testing and administrative aspects that 401(k) administrators need to know.

The Qualified Pension Administrator program (QPA) encompasses technical administration, compliance and reporting functions for all types of qualified plans.

The Certified Pension Consultant program (CPC) covers all qualified plan aspects in great depth to provide the detailed knowledge that a plan consultant would utilize in areas of plan design, administration and in fulfilling departmental leadership roles for compliance, relationship management, plan documents and operations.

Financial Consulting Track



The Qualified Plan Financial Consultant program (QPFC) focuses primarily on the aspects of retirement planning, administration and regulatory requirements that consultants who provide plan design, sales, sales support or financial consulting need to know.

Tax-Exempt & Governmental Plan Administration, Compliance and Consulting Track

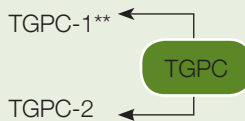

The Tax-Exempt & Governmental Plan Consultant (TGPC) program encompasses issues affecting the administration, sales and marketing aspects of 403(b), 457(b) and other plans maintained by tax-exempt and governmental entities.

Actuarial Consulting Track

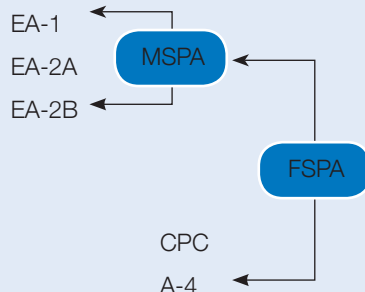

The Member, Society of Pension Actuaries credential (MSPA) was created for individuals providing defined benefit or actuarial consulting who are currently Enrolled Actuaries in good standing.

The Fellow, Society of Pension Actuaries program (FSPA) was designed for MSPAs who wish to enhance their qualified plan analytical and consulting skills.

*Successful completion of RPF-1 and RPF-2 earns a candidate the Retirement Plan Fundamentals Certificate.

** Successful completion of TGPC-1 earns a candidate the Tax-exempt & Governmental Plan Administration Certificate.

†Successful completion of PFC-1 earns a candidate the Plan Financial Consulting Certificate.

Questions? Contact education@asppa.org or visit us at www.asppa.org.